

Easy UPS 3M and Easy UPS 3L

Battery Breaker Kit

Installation

E3MBBK60K80H, E3MBBK100K200H

Always go to www.se.com for the latest update and localized versions of the manual

1/2021

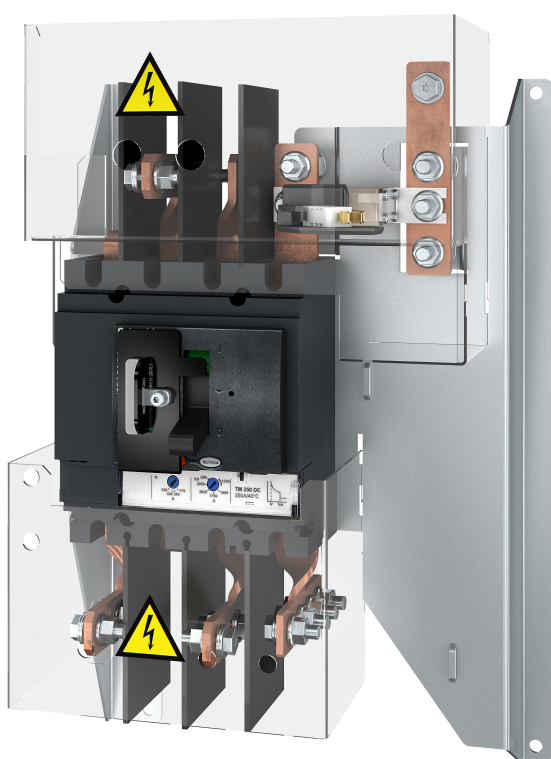

Legal Information

The Schneider Electric brand and any trademarks of Schneider Electric SE and its subsidiaries referred to in this guide are the property of Schneider Electric SE or its subsidiaries. All other brands may be trademarks of their respective owners.

This guide and its content are protected under applicable copyright laws and furnished for informational use only. No part of this guide may be reproduced or transmitted in any form or by any means (electronic, mechanical, photocopying, recording, or otherwise), for any purpose, without the prior written permission of Schneider Electric.

Schneider Electric does not grant any right or license for commercial use of the guide or its content, except for a non-exclusive and personal license to consult it on an "as is" basis. Schneider Electric products and equipment should be installed, operated, serviced, and maintained only by qualified personnel.

As standards, specifications, and designs change from time to time, information contained in this guide may be subject to change without notice.

To the extent permitted by applicable law, no responsibility or liability is assumed by Schneider Electric and its subsidiaries for any errors or omissions in the informational content of this material or consequences arising out of or resulting from the use of the information contained herein.

Table of Contents

Important Safety Instructions — SAVE THESE	
INSTRUCTIONS	5
Electromagnetic Compatibility	6
Safety Precautions	6
Electrical Safety	8
Battery Safety	9
Specifications	11
Battery Breaker Kit Specifications	11
Battery Breaker Kit Weights and Dimensions	11
Trip Settings	12
Trip Settings for Operation with Easy UPS 3M 400 V	12
Trip Settings for Operation with Easy UPS 3M 208 V	14
Trip Settings for Operation with Easy UPS 3L at Power Factor	
1.0	15
Trip Settings for Operation with Easy UPS 3L at Power Factor	
0.9	22
Recommended Cable Sizes for 400 V	29
Recommended Cable Sizes for 208 V	31
Torque Specifications	32
Environment	32
Installation Procedure	33
Mount the Battery Breaker Kit in a Grounded Metal Box	34
Mount the Battery Breaker in the Empty Battery Cabinet –	
Bottom Cable Entry	35
Mount the Battery Breaker in the Empty Battery Cabinet – Top	
Cable Entry	36
Connect the Signal Cables	37
Connect the Power Cables	40

Important Safety Instructions — SAVE THESE INSTRUCTIONS

Read these instructions carefully and look at the equipment to become familiar with it before trying to install, operate, service or maintain it. The following safety messages may appear throughout this manual or on the equipment to warn of potential hazards or to call attention to information that clarifies or simplifies a procedure.



The addition of this symbol to a “Danger” or “Warning” safety message indicates that an electrical hazard exists which will result in personal injury if the instructions are not followed.



This is the safety alert symbol. It is used to alert you to potential personal injury hazards. Obey all safety messages with this symbol to avoid possible injury or death.

DANGER

DANGER indicates a hazardous situation which, if not avoided, **will result in death or serious injury.**

Failure to follow these instructions will result in death or serious injury.

WARNING

WARNING indicates a hazardous situation which, if not avoided, **could result in death or serious injury.**

Failure to follow these instructions can result in death, serious injury, or equipment damage.

CAUTION

CAUTION indicates a hazardous situation which, if not avoided, **could result in minor or moderate injury.**

Failure to follow these instructions can result in injury or equipment damage.

NOTICE

NOTICE is used to address practices not related to physical injury. The safety alert symbol shall not be used with this type of safety message.

Failure to follow these instructions can result in equipment damage.

Please Note

Electrical equipment should only be installed, operated, serviced, and maintained by qualified personnel. No responsibility is assumed by Schneider Electric for any consequences arising out of the use of this material.

A qualified person is one who has skills and knowledge related to the construction, installation, and operation of electrical equipment and has received safety training to recognize and avoid the hazards involved.

Electromagnetic Compatibility

NOTICE

RISK OF ELECTROMAGNETIC DISTURBANCE

This is a product Category C3 according to IEC 62040-2. This is a product for commercial and industrial applications in the second environment - installation restrictions or additional measures may be needed to prevent disturbances. The second environment includes all commercial, light industry, and industrial locations other than residential, commercial, and light industrial premises directly connected without intermediate transformer to a public low-voltage mains supply. The installation and cabling must follow the electromagnetic compatibility rules, e.g.:

- the segregation of cables,
- the use of shielded or special cables when relevant,
- the use of grounded metallic cable tray and supports.

Failure to follow these instructions can result in equipment damage.

Safety Precautions

DANGER

HAZARD OF ELECTRIC SHOCK, EXPLOSION, OR ARC FLASH

Read all instructions in the installation manual before installing or working on this product.

Failure to follow these instructions will result in death or serious injury.

DANGER

HAZARD OF ELECTRIC SHOCK, EXPLOSION, OR ARC FLASH

Do not install the product until all construction work has been completed and the installation room has been cleaned.

Failure to follow these instructions will result in death or serious injury.

DANGER

HAZARD OF ELECTRIC SHOCK, EXPLOSION, OR ARC FLASH

The product must be installed according to the specifications and requirements as defined by Schneider Electric. It concerns in particular the external and internal protections (upstream breakers, battery breakers, cabling, etc.) and environmental requirements. No responsibility is assumed by Schneider Electric if these requirements are not respected.

Failure to follow these instructions will result in death or serious injury.

⚠️⚠️ DANGER

HAZARD OF ELECTRIC SHOCK, EXPLOSION, OR ARC FLASH

The UPS system must be installed according to local and national regulations. Install the UPS according to:

- IEC 60364 (including 60364-4-41 - protection against electric shock, 60364-4-42 - protection against thermal effect, and 60364-4-43 - protection against overcurrent), or
- NEC NFPA 70, or
- Canadian Electrical Code (C22.1, Part 1)

depending on which one of the standards apply in your local area.

Failure to follow these instructions will result in death or serious injury.

⚠️⚠️ DANGER

HAZARD OF ELECTRIC SHOCK, EXPLOSION, OR ARC FLASH

- Install the product in a temperature controlled indoor environment free of conductive contaminants and humidity.
- Install the product on a non-flammable, level and solid surface (e.g. concrete) that can support the weight of the system.

Failure to follow these instructions will result in death or serious injury.

⚠️⚠️ DANGER

HAZARD OF ELECTRIC SHOCK, EXPLOSION, OR ARC FLASH

The product is not designed for and must therefore not be installed in the following unusual operating environments:

- Damaging fumes
- Explosive mixtures of dust or gases, corrosive gases, or conductive or radiant heat from other sources
- Moisture, abrasive dust, steam or in an excessively damp environment
- Fungus, insects, vermin
- Salt-laden air or contaminated cooling refrigerant
- Pollution degree higher than 2 according to IEC 60664-1
- Exposure to abnormal vibrations, shocks, and tilting
- Exposure to direct sunlight, heat sources, or strong electromagnetic fields

Failure to follow these instructions will result in death or serious injury.

⚠️⚠️ DANGER

HAZARD OF ELECTRIC SHOCK, EXPLOSION, OR ARC FLASH

Do not drill or cut holes for cables or conduits with the gland plates installed and do not drill or cut holes in close proximity to the UPS.

Failure to follow these instructions will result in death or serious injury.

⚠️⚠️ WARNING

HAZARD OF ARC FLASH

Do not make mechanical changes to the product (including removal of cabinet parts or drilling/cutting of holes) that are not described in the installation manual.

Failure to follow these instructions can result in death, serious injury, or equipment damage.

NOTICE**RISK OF OVERHEATING**

Respect the space requirements around the product and do not cover the ventilation openings when the product is in operation.

Failure to follow these instructions can result in equipment damage.

Electrical Safety**⚠ DANGER****HAZARD OF ELECTRIC SHOCK, EXPLOSION, OR ARC FLASH**

- Electrical equipment must be installed, operated, serviced, and maintained only by qualified personnel.
- Apply appropriate personal protective equipment (PPE) and follow safe electrical work practices.
- Turn off all power supplying the UPS system before working on or inside the equipment.
- Before working on the UPS system, check for hazardous voltage between all terminals including the protective earth.
- The UPS contains an internal energy source. Hazardous voltage can be present even when disconnected from the mains supply. Before installing or servicing the UPS system, ensure that the units are OFF and that mains and batteries are disconnected. Wait five minutes before opening the UPS to allow the capacitors to discharge.
- A disconnection device (e.g. disconnection circuit breaker or switch) must be installed to enable isolation of the system from upstream power sources in accordance with local regulations. The disconnection device must be easily accessible and visible.
- The UPS must be properly earthed/grounded and due to a high leakage current, the earthing/grounding conductor must be connected first.

Failure to follow these instructions will result in death or serious injury.

⚠ DANGER**HAZARD OF ELECTRIC SHOCK, EXPLOSION, OR ARC FLASH**

In systems where backfeed protection is not part of the standard design, an automatic isolation device (backfeed protection option or other device meeting the requirements of IEC/EN 62040-1 or UL1778 5th Edition – depending on which of the two standards apply to your local area) must be installed to prevent hazardous voltage or energy at the input terminals of the isolation device. The device must open within 15 seconds after the upstream power supply fails and must be rated according to the specifications.

Failure to follow these instructions will result in death or serious injury.

When the UPS input is connected through external isolators that, when opened, isolate the neutral or when the automatic backfeed isolation is provided external to the equipment or is connected to an IT power distribution system, a label must be fitted at the UPS input terminals, and on all primary power isolators installed remote from the UPS area and on external access points between such isolators and the UPS, by the user, displaying the following text (or equivalent in a language which is acceptable in the country in which the UPS system is installed):

⚠ DANGER

HAZARD OF ELECTRIC SHOCK, EXPLOSION, OR ARC FLASH

Risk of Voltage Backfeed. Before working on this circuit: Isolate the UPS and check for hazardous voltage between all terminals including the protective earth.

Failure to follow these instructions will result in death or serious injury.

Battery Safety

⚠⚠ DANGER

HAZARD OF ELECTRIC SHOCK, EXPLOSION OR ARC FLASH

- Battery circuit breakers must be installed according to the specifications and requirements as defined by Schneider Electric.
- Servicing of batteries must only be performed or supervised by qualified personnel knowledgeable of batteries and the required precautions. Keep unqualified personnel away from batteries.
- Disconnect charging source prior to connecting or disconnecting battery terminals.
- Do not dispose of batteries in a fire as they can explode.
- Failed batteries can reach temperatures that exceed the burn thresholds for touchable surfaces.
- Do not open, alter, or mutilate batteries. Released electrolyte is harmful to the skin and eyes. It may be toxic.

Failure to follow these instructions will result in death or serious injury.

⚠⚠ DANGER

HAZARD OF ELECTRIC SHOCK, EXPLOSION, OR ARC FLASH

Batteries can present a risk of electric shock and high short-circuit current. The following precautions must be observed when working on batteries:

- Remove watches, rings, or other metal objects.
- Use tools with insulated handles.
- Wear protective glasses, gloves, and boots.
- Do not lay tools or metal parts on top of batteries.
- Disconnect the charging source prior to connecting or disconnecting battery terminals.
- Determine if the battery is inadvertently grounded. If inadvertently grounded, remove source from ground. Contact with any part of a grounded battery can result in electric shock and burns by high short-circuit current. The likelihood of such shock can be reduced if such grounds are removed during installation and maintenance by a skilled person (applicable to equipment and remote battery supplies not having a grounded supply circuit).

Failure to follow these instructions will result in death or serious injury.

⚠⚠ DANGER

HAZARD OF ELECTRIC SHOCK, EXPLOSION, OR ARC FLASH

When replacing batteries, always replace with the same type and number of batteries or battery packs. Refer to the label in the classic battery cabinet for information on batteries in your system.

Failure to follow these instructions will result in death or serious injury.

▲ CAUTION**RISK OF EQUIPMENT DAMAGE**

- Wait until the system is ready to be powered up before installing batteries in the system. The time duration from battery installation until the UPS system is powered up must not exceed 72 hours or 3 days.
- Batteries must not be stored more than six months due to the requirement of recharging. If the UPS system remains de-energized for a long period, we recommend that you energize the UPS system for a period of 24 hours at least once every month. This charges the batteries, thus avoiding irreversible damage.

Failure to follow these instructions can result in injury or equipment damage.

Specifications

NOTICE
HAZARD OF EQUIPMENT DAMAGE
Refer to the UPS installation manual for detailed specifications for the UPS system.
Failure to follow these instructions can result in equipment damage.

Battery Breaker Kit Specifications

⚠ DANGER
HAZARD OF ELECTRIC SHOCK, EXPLOSION, OR ARC FLASH
This product must only be used with the Easy UPS 3M and Easy UPS 3L.
Failure to follow these instructions will result in death or serious injury.

NOTE: A maximum of four battery strings can be connected to the battery breaker.

	E3MBBK60K80H	E3MBBK100K200H
Battery breaker	Compact NSX250S DC (LV438990)	Compact NSX630S DC (LV438274)
Maximum configuration	4 hours runtime	4 hours runtime for 40–50 battery blocks 1 hour runtime for 36–38 battery blocks
Battery type	VRLA	
Maximum battery short-circuit level (kA)	20 kA	
Minimum short-circuit current to trip the circuit breaker (A)	1250	1500

Battery Breaker Kit Weights and Dimensions

	Weight kg	Height mm	Width mm	Depth mm
Battery breaker kit E3MBBK60K80H	7	415	288	190
Battery breaker kit E3MBBK100K200H	13	530	320	230

Trip Settings

E3MBBK60K80H

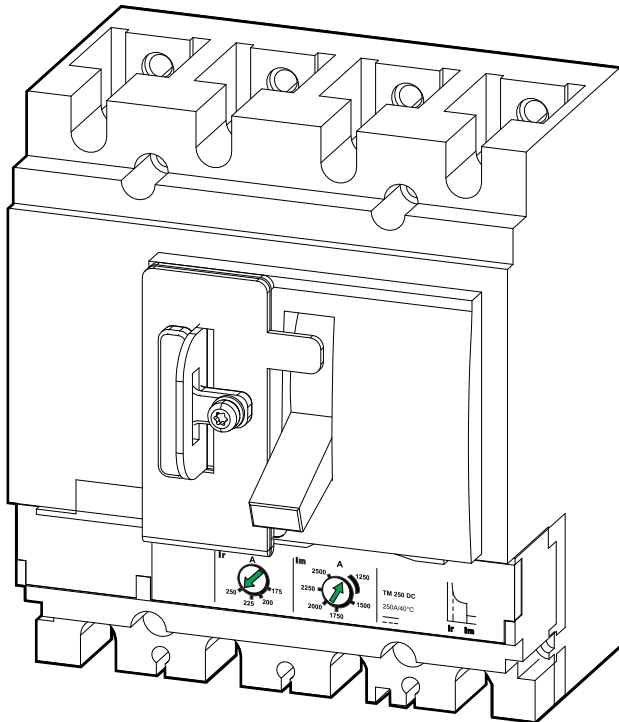

E3MBBK100K200H

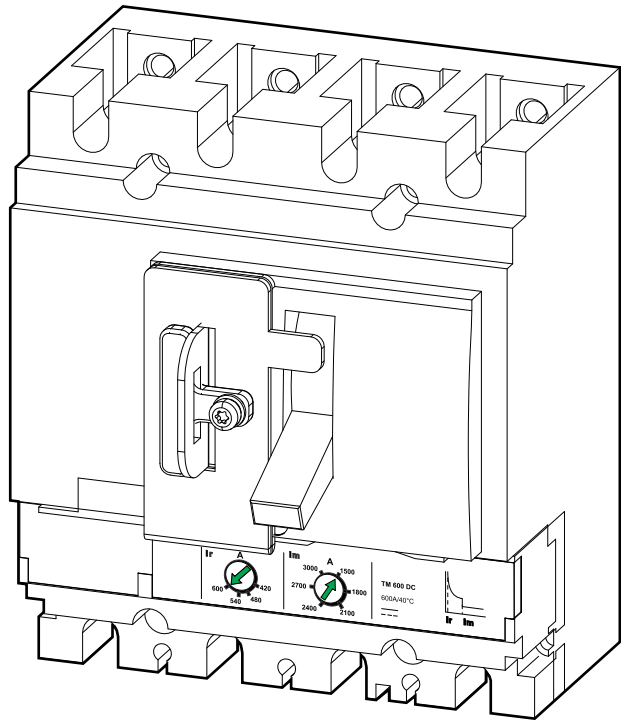

Trip Settings for Operation with Easy UPS 3M 400 V

With One Battery Breaker Kit E3MBBK60K80H

UPS rating	Max Battery Backup Time (minutes)	Battery Blocks	Battery Strings	Ir/Im Setting (A)
60 kVA	240	32-50	1/2/3/4	200/1250
80 kVA	240	32-50	1/2/3/4	250/1250

With One Battery Breaker Kit E3MBBK100K200H

UPS rating	Max Battery Backup Time (minutes)	Battery Blocks	Battery Strings	Ir/Im Setting (A)
100 kVA	240	36-50	1/2/3/4	420/1500
120 kVA	240	36-50	1/2/3/4	420/1500
160 kVA	240	36-50	1/2/3/4	480/1500
200 kVA	60	36-38	1/2/3/4	600/1500
	240	40-50	1/2/3/4	600/1500

With Two Battery Breaker Kits E3MBBK60K80H

UPS rating	Max Battery Backup Time (minutes)	Battery Blocks	Battery Strings Total	Battery Breaker 1		Battery Breaker 2	
				Battery Strings	Ir/Im Setting (A)	Battery Strings	Ir/Im Setting (A)
60 kVA	240	32-50	5	3	175/1250	2	175/1250
	240	32-50	6	3	175/1250	3	175/1250

UPS rating	Max Battery Backup Time (minutes)	Battery Blocks	Battery Strings Total	Battery Breaker 1		Battery Breaker 2	
				Battery Strings	Ir/Im Setting (A)	Battery Strings	Ir/Im Setting (A)
	240	32-50	7	4	175/1250	3	175/1250
	240	32-50	8	4	175/1250	4	175/1250
80 kVA	240	32-50	5	3	175/1250	2	175/1250
	240	32-50	6	3	175/1250	3	175/1250
	240	32-50	7	4	175/1250	3	175/1250
	240	32-50	8	4	175/1250	4	175/1250
100 kVA	240	36-50	5	3	200/1250	2	175/1250
	240	32-50	6	3	175/1250	3	175/1250
	240	32-50	7	4	175/1250	3	175/1250
	240	32-50	8	4	175/1250	4	175/1250
120 kVA	240	32-50	5	3	225/1250	2	175/1250
	240	32-50	6	3	200/1250	3	200/1250
	240	32-50	7	4	225/1250	3	175/1250
	240	32-50	8	4	200/1250	4	200/1250
160 kVA	5	32-36	5	3	250/1250	2	200/1250
	10	38	5	3	250/1250	2	200/1250
	15	40	5	3	250/1250	2	175/1250
	240	42-50	5	3	250/1250	2	175/1250
	240	32-50	6	3	250/1250	3	250/1250
	10	32-36	7	4	250/1250	3	225/1250
	15	38	7	4	250/1250	3	200/1250
	240	40-50	7	4	250/1250	3	200/1250
	240	32-50	8	4	250/1250	4	250/1250

With Two Battery Breaker Kits E3MBBK100K200H

UPS rating	Max Battery Backup Time (minutes)	Battery Blocks	Battery Strings Total	Battery Breaker 1		Battery Breaker 2	
				Battery Strings	Ir/Im Setting (A)	Battery Strings	Ir/Im Setting (A)
120 kVA	240	32-50	5	3	420/1500	2	420/1500
	240	32-50	6	3	420/1500	3	420/1500
	240	32-50	7	4	420/1500	3	420/1500
	240	32-50	8	4	420/1500	4	420/1500
160 kVA	240	32-50	5	3	420/1500	2	420/1500
	240	32-50	6	3	420/1500	3	420/1500
	240	32-50	7	4	420/1500	3	420/1500
	240	32-50	8	4	420/1500	4	420/1500
200 kVA	240	36-50	5	3	420/1500	2	420/1500
	240	32-50	6	3	420/1500	3	420/1500
	240	32-50	7	4	420/1500	3	420/1500
	240	32-50	8	4	420/1500	4	420/1500

Trip Settings for Operation with Easy UPS 3M 208 V

With One Battery Breaker Kit E3MBBK60K80H

UPS rating	Max Battery Backup Time (minutes)	Battery Blocks	Battery Strings	Ir/Im Setting (A)
50 kVA	240	32-40	1/2/3/4	200/1250
60 kVA	240	32-40	1/2/3/4	220/1250

With One Battery Breaker Kit E3MBBK100K200H

UPS rating	Max Battery Backup Time (minutes)	Battery Blocks	Battery Strings	Ir/Im Setting (A)
80 kVA	240	32-40	1/2/3/4	420/1500
100 kVA	240	32-40	1/2/3/4	420/1500

With Two Battery Breaker Kits E3MBBK60K80H

UPS rating	Max Battery Backup Time (minutes)	Battery Blocks	Battery Strings Total	Battery Breaker 1		Battery Breaker 2	
				Battery Strings	Ir/Im Setting (A)	Battery Strings	Ir/Im Setting (A)
50 kVA	240	32-40	5	3	175/1250	2	175/1250
	240	32-40	6	3	175/1250	3	175/1250
	240	32-40	7	4	175/1250	3	175/1250
	240	32-40	8	4	175/1250	4	175/1250
60 kVA	240	32-40	5	3	175/1250	2	175/1250
	240	32-40	6	3	175/1250	3	175/1250
	240	32-40	7	4	175/1250	3	175/1250
	240	32-40	8	4	175/1250	4	175/1250
80 kVA	240	32-40	5	3	175/1250	2	175/1250
	240	32-40	6	3	175/1250	3	175/1250
	240	32-40	7	4	175/1250	3	175/1250
	240	32-40	8	4	175/1250	4	175/1250
100 kVA	240	32-40	5	3	200/1250	2	200/1250
	240	32-40	6	3	200/1250	3	200/1250
	240	32-40	7	4	200/1250	3	200/1250
	240	32-40	8	4	200/1250	4	200/1250

Trip Settings for Operation with Easy UPS 3L at Power Factor 1.0

With One Battery Breaker Kit E3MBBK100K200H

UPS rating 250 kVA

Max Battery Backup Time (minutes)	Battery Blocks	Battery Strings Total	Battery Breaker	
			Battery Strings	Ir/Im Setting (A)
≤10	36-38	1-4	1-4	600/1500
≤15	40	1-4	1-4	600/1500
≤30	42	1-4	1-4	600/1500
240	44-50	1-4	1-4	600/1500

UPS rating 300 kVA

Max Battery Backup Time (minutes)	Battery Blocks	Battery Strings Total	Battery Breaker	
			Battery Strings	Ir/Im Setting (A)
≤5	38-42	1-4	1-4	600/1500
≤10	44-46	1-4	1-4	600/1500
≤15	48-50	1-4	1-4	600/1500

UPS rating 400 kVA

Max Battery Backup Time (minutes)	Battery Blocks	Battery Strings Total	Battery Breaker	
			Battery Strings	Ir/Im Setting (A)
≤5	50	1-4	1-4	600/1500

With Two Battery Breaker Kits E3MBBK100K200H

UPS rating 250 kVA

Max Battery Backup Time (minutes)	Battery Blocks	Battery Strings Total	Battery Breaker 1		Battery Breaker 2	
			Battery Strings	Ir/Im Setting (A)	Battery Strings	Ir/Im Setting (A)
240	36-50	2	1	420/1500	1	420/1500
240	36	3	2	540/1500	1	420/1500
240	38-42	3	2	480/1500	1	420/1500
240	44-50	3	2	420/1500	1	420/1500
240	36-50	4	2	420/1500	2	420/1500
240	36-38	5	3	480/1500	2	420/1500
240	40-50	5	3	420/1500	2	420/1500
240	36-50	6	3	420/1500	3	420/1500
240	36	7	4	480/1500	3	420/1500
240	38-50	7	4	420/1500	3	420/1500
240	36-50	8	4	420/1500	4	420/1500

UPS rating 300 kVA

Max Battery Backup Time (minutes)	Battery Blocks	Battery Strings Total	Battery Breaker 1		Battery Breaker 2	
			Battery Strings	Ir/Im Setting (A)	Battery Strings	Ir/Im Setting (A)
240	36-38	2	1	480/1500	1	480/1500
240	40-50	2	1	420/1500	1	420/1500
240	36-40	3	2	600/1500	1	420/1500
240	42-44	3	2	540/1500	1	420/1500
240	46-50	3	2	480/1500	1	420/1500
240	36-38	4	2	480/1500	2	480/1500
240	40-50	4	2	420/1500	2	420/1500
240	36	5	3	600/1500	2	420/1500
240	38-40	5	3	540/1500	2	420/1500
240	42-46	5	3	480/1500	2	420/1500
240	48-50	5	3	420/1500	2	420/1500
240	36-38	6	3	480/1500	3	480/1500
240	40-50	6	3	420/1500	3	420/1500
240	36-38	7	4	540/1500	3	420/1500
240	40-44	7	4	480/1500	3	420/1500
240	46-50	7	4	420/1500	3	420/1500
240	36-38	8	4	480/1500	4	480/1500
240	40-50	8	4	420/1500	4	420/1500

UPS rating 400 kVA

Max Battery Backup Time (minutes)	Battery Blocks	Battery Strings Total	Battery Breaker 1		Battery Breaker 2	
			Battery Strings	Ir/Im Setting (A)	Battery Strings	Ir/Im Setting (A)
240	36-40	2	1	600/1500	1	600/1500
240	42-44	2	1	540/1500	1	540/1500
240	46-50	2	1	480/1500	1	480/1500
5	36	3	2	600/1500	1	420/1500
10	38-40	3	2	600/1500	1	420/1500
15	42-44	3	2	600/1500	1	420/1500
30	46	3	2	600/1500	1	420/1500
240	48-50	3	2	600/1500	1	420/1500
240	36-40	4	2	600/1500	2	600/1500
240	42-44	4	2	540/1500	2	540/1500
240	46-50	4	2	480/1500	2	480/1500
10	36	5	3	600/1500	2	540/1500
15	38-40	5	3	600/1500	2	480/1500
30	42	5	3	600/1500	2	420/1500
240	44-50	5	3	600/1500	2	420/1500
240	36-40	6	3	600/1500	3	600/1500
240	42-44	6	3	540/1500	3	540/1500
240	46-50	6	3	480/1500	3	480/1500
15	36-38	7	4	600/1500	3	540/1500
30	40	7	4	600/1500	3	480/1500
240	42-46	7	4	600/1500	3	480/1500
240	48-50	7	4	540/1500	3	420/1500
240	36-40	8	4	600/1500	4	600/1500
240	42-44	8	4	540/1500	4	540/1500
240	46-50	8	4	480/1500	4	480/1500

UPS rating 500 kVA

Max Battery Backup Time (minutes)	Battery Blocks	Battery Strings Total	Battery Breaker 1		Battery Breaker 2	
			Battery Strings	Ir/Im Setting (A)	Battery Strings	Ir/Im Setting (A)
10	36-38	2	1	600/1500	1	600/1500
15	40	2	1	600/1500	1	600/1500
30	42	2	1	600/1500	1	600/1500
240	44-50	2	1	600/1500	1	600/1500
5	42-46	3	2	600/1500	1	480/1500
10	48-50	3	2	600/1500	1	420/1500
10	36-38	4	2	600/1500	2	600/1500
15	40	4	2	600/1500	2	600/1500
30	42	4	2	600/1500	2	600/1500
240	44-50	4	2	600/1500	2	600/1500
5	38-42	5	3	600/1500	2	600/1500
10	44-46	5	3	600/1500	2	540/1500
15	48-50	5	3	600/1500	2	480/1500
10	36-38	6	3	600/1500	3	600/1500
15	40	6	3	600/1500	3	600/1500
30	42	6	3	600/1500	3	600/1500
240	44-50	6	3	600/1500	3	600/1500
5	36-40	7	4	600/1500	3	600/1500
10	42	7	4	600/1500	3	600/1500
15	44-46	7	4	600/1500	3	540/1500
30	48-50	7	4	600/1500	3	540/1500
10	36-38	8	4	600/1500	4	600/1500
15	40	8	4	600/1500	4	600/1500
30	42	8	4	600/1500	4	600/1500
240	44-50	8	4	600/1500	4	600/1500

UPS rating 600 kVA

Max Battery Backup Time (minutes)	Battery Blocks	Battery Strings Total	Battery Breaker 1		Battery Breaker 2	
			Battery Strings	Ir/Im Setting (A)	Battery Strings	Ir/Im Setting (A)
5	38-42	2	1	600/1500	1	600/1500
10	44-46	2	1	600/1500	1	600/1500
15	48-50	2	1	600/1500	1	600/1500
5	50	3	2	600/1500	1	480/1500
5	38-42	4	2	600/1500	2	600/1500
10	44-46	4	2	600/1500	2	600/1500
15	48-50	4	2	600/1500	2	600/1500
5	46-50	5	3	600/1500	2	540/1500
5	38-42	6	3	600/1500	3	600/1500
10	44-46	6	3	600/1500	3	600/1500
15	48-50	6	3	600/1500	3	600/1500
5	44-48	7	4	600/1500	3	600/1500
10	50	7	4	600/1500	3	600/1500
5	38-42	8	4	600/1500	4	600/1500
10	44-46	8	4	600/1500	4	600/1500
15	48-50	8	4	600/1500	4	600/1500

With Three Battery Breaker Kits E3MBBK100K200H

UPS rating 500 kVA

Max Battery Backup Time (minutes)	Battery Blocks	Battery Strings Total	Battery Breaker 1		Battery Breaker 2		Battery Breaker 3	
			Battery Strings	Ir/Im Setting (A)	Battery Strings	Ir/Im Setting (A)	Battery Strings	Ir/Im Setting (A)
60	36-38	3	1	540/1500	1	540/1500	1	540/1500
240	40-50	3	1	540/1500	1	540/1500	1	540/1500
10	36-38	4	2	600/1500	1	420/1500	1	420/1500
15	40	4	2	600/1500	1	420/1500	1	420/1500
30	42	4	2	600/1500	1	420/1500	1	420/1500
240	44-50	4	2	600/1500	1	420/1500	1	420/1500
60	36-38	5	2	600/1500	2	600/1500	1	420/1500
240	40-50	5	2	600/1500	2	600/1500	1	420/1500
60	36-38	6	2	540/1500	2	540/1500	2	540/1500
240	40-50	6	2	540/1500	2	540/1500	2	540/1500
30	36	7	3	600/1500	2	480/1500	2	480/1500
60	36-38	7	3	600/1500	2	420/1500	2	420/1500
240	40-50	7	3	600/1500	2	420/1500	2	420/1500
60	36-38	8	3	600/1500	3	600/1500	2	420/1500
240	40-50	8	3	600/1500	3	600/1500	2	420/1500
60	36-38	9	3	540/1500	3	540/1500	3	540/1500
240	40-50	9	3	540/1500	3	540/1500	3	540/1500
60	36-38	10	4	600/1500	3	480/1500	3	480/1500
240	40-50	10	4	600/1500	3	480/1500	3	480/1500
60	36-38	11	4	600/1500	4	600/1500	3	420/1500
240	40-50	11	4	600/1500	4	600/1500	3	420/1500
60	36-38	12	4	540/1500	4	540/1500	4	540/1500
240	40-50	12	4	540/1500	4	540/1500	4	540/1500

UPS rating 600 kVA

Max Battery Backup Time (minutes)	Battery Blocks	Battery Strings Total	Battery Breaker 1		Battery Breaker 2		Battery Breaker 3	
			Battery Strings	Ir/Im Setting (A)	Battery Strings	Ir/Im Setting (A)	Battery Strings	Ir/Im Setting (A)
60	36-38	3	1	600/1500	1	600/1500	1	600/1500
240	40-50	3	1	600/1500	1	600/1500	1	600/1500
5	38-42	4	2	600/1500	1	480/1500	1	480/1500
10	44-46	4	2	600/1500	1	420/1500	1	420/1500
15	48-50	4	2	600/1500	1	420/1500	1	420/1500
10	36	5	2	600/1500	2	600/1500	1	420/1500
15	38-40	5	2	600/1500	2	600/1500	1	420/1500
30	42	5	2	600/1500	2	600/1500	1	420/1500
240	44-50	5	2	600/1500	2	600/1500	1	420/1500
60	36-38	6	2	600/1500	2	600/1500	2	600/1500
240	40-50	6	2	600/1500	2	600/1500	2	600/1500
5	36	7	3	600/1500	2	540/1500	2	540/1500
10	38	7	3	600/1500	2	540/1500	2	540/1500
15	40-42	7	3	600/1500	2	480/1500	2	480/1500
30	44	7	3	600/1500	2	480/1500	2	480/1500
240	46-50	7	3	600/1500	2	420/1500	2	420/1500
15	36	8	3	600/1500	3	600/1500	2	480/1500
30	38	8	3	600/1500	3	600/1500	2	480/1500
240	40-50	8	3	600/1500	3	600/1500	2	420/1500
60	36-38	9	3	600/1500	3	600/1500	3	600/1500
240	40-50	9	3	600/1500	3	600/1500	3	600/1500
10	36	10	4	600/1500	3	600/1500	3	600/1500
15	38-40	10	4	600/1500	3	540/1500	3	540/1500
30	42	10	4	600/1500	3	480/1500	3	480/1500
240	44-50	10	4	600/1500	3	480/1500	3	480/1500
15	36	11	4	600/1500	4	600/1500	3	540/1500
30	38	11	4	600/1500	4	600/1500	3	480/1500
240	40-50	11	4	600/1500	4	600/1500	3	480/1500
60	36-38	12	4	600/1500	4	600/1500	4	600/1500
240	40-50	12	4	600/1500	4	600/1500	4	600/1500

Trip Settings for Operation with Easy UPS 3L at Power Factor 0.9

With One Battery Breaker Kit E3MBBK100K200H

UPS rating 250 kVA

Max Battery Backup Time (minutes)	Battery Blocks	Battery Strings Total	Battery Breaker	
			Battery Strings	Ir/Im Setting (A)
15	36	1-4	1-4	600/1500
30	38	1-4	1-4	600/1500
240	40-44	1-4	1-4	600/1500
240	46-50	1-4	1-4	540/1500

UPS rating 300 kVA

Max Battery Backup Time (minutes)	Battery Blocks	Battery Strings Total	Battery Breaker	
			Battery Strings	Ir/Im Setting (A)
5	36-38	1-4	1-4	600/1500
10	40	1-4	1-4	600/1500
15	42-44	1-4	1-4	600/1500
30	46	1-4	1-4	600/1500
240	48-50	1-4	1-4	600/1500

UPS rating 400 kVA

Max Battery Backup Time (minutes)	Battery Blocks	Battery Strings Total	Battery Breaker	
			Battery Strings	Ir/Im Setting (A)
5	46-50	1-4	1-4	600/1500

With Two Battery Breaker Kits E3MBBK100K200H

UPS rating 250 kVA

Max Battery Backup Time (minutes)	Battery Blocks	Battery Strings Total	Battery Breaker 1		Battery Breaker 2	
			Battery Strings	Ir/Im Setting (A)	Battery Strings	Ir/Im Setting (A)
60/240	36-38/40-50	2	1	420/1500	1	420/1500
60	36-38	3	2	480/1500	1	420/1500
60/240	36-38/40-50	3	2	420/1500	1	420/1500
60/240	36-38/40-50	4	2	420/1500	2	420/1500
60/240	36-38/40-50	5	3	420/1500	2	420/1500
60/240	36-38/40-50	6	3	420/1500	3	420/1500
60/240	36-38/40-50	7	4	420/1500	3	420/1500
60/240	36-38/40-50	8	4	420/1500	4	420/1500

UPS rating 300 kVA

Max Battery Backup Time (minutes)	Battery Blocks	Battery Strings Total	Battery Breaker 1		Battery Breaker 2	
			Battery Strings	Ir/Im Setting (A)	Battery Strings	Ir/Im Setting (A)
60/240	36-38/40-50	2	1	420/1500	1	420/1500
60	36	3	2	600/1500	1	420/1500
60/240	38/40-50	3	2	540/1500	1	420/1500
240	42-46	3	2	480/1500	1	420/1500
240	48-50	3	2	420/1500	1	420/1500
60/240	36-38/40-50	4	2	420/1500	2	420/1500
60	36	5	3	540/1500	2	420/1500
60/240	38/40-50	5	3	480/1500	2	420/1500
240	42-50	5	3	420/1500	2	420/1500
60/240	36-38/40-50	6	3	420/1500	3	420/1500
60	36-38	7	4	480/1500	3	420/1500
240	40-50	7	4	420/1500	3	420/1500
60/240	36-38/40-50	8	4	420/1500	4	420/1500

UPS rating 400 kVA

Max Battery Backup Time (minutes)	Battery Blocks	Battery Strings Total	Battery Breaker 1		Battery Breaker 2	
			Battery Strings	Ir/Im Setting (A)	Battery Strings	Ir/Im Setting (A)
60	36	2	1	600/1500	1	600/1500
60/240	38/40	2	1	540/1500	1	540/1500
240	42-46	2	1	480/1500	1	480/1500
240	48-50	2	1	420/1500	1	420/1500
10	36	3	2	600/1500	1	420/1500
15	38-40	3	2	600/1500	1	420/1500
30	42	3	2	600/1500	1	420/1500
240	44-48	3	2	600/1500	1	420/1500
240	50	3	2	540/1500	1	420/1500
60	36	4	2	600/1500	2	600/1500
60/240	38/40	4	2	540/1500	2	540/1500
240	42-46	4	2	480/1500	2	480/1500
240	48-50	4	2	420/1500	2	420/1500
15	36	5	3	600/1500	2	480/1500
60/240	38/40-42	5	3	600/1500	2	420/1500
240	44-48	5	3	540/1500	2	420/1500
240	50	5	3	480/1500	2	420/1500
60	36	6	3	600/1500	3	600/1500
60/240	38/40	6	3	540/1500	3	540/1500
240	42-46	6	3	480/1500	3	480/1500
240	48-50	6	3	420/1500	3	420/1500
30	36	7	4	600/1500	3	480/1500
60/240	38/40	7	4	600/1500	3	480/1500
240	42-46	7	4	540/1500	3	420/1500
240	48-50	7	4	480/1500	3	420/1500
60	36	8	4	600/1500	4	600/1500
60/240	38/40	8	4	540/1500	4	540/1500
240	42-46	8	4	480/1500	4	480/1500
240	48-50	8	4	420/1500	4	420/1500

UPS rating 500 kVA

Max Battery Backup Time (minutes)	Battery Blocks	Battery Strings Total	Battery Breaker 1		Battery Breaker 2	
			Battery Strings	Ir/Im Setting (A)	Battery Strings	Ir/Im Setting (A)
15	36	2	1	600/1500	1	600/1500
30	38	2	1	600/1500	1	600/1500
240	40-50	2	1	600/1500	1	600/1500
5	38-42	3	2	600/1500	1	480/1500
10	44-46	3	2	600/1500	1	420/1500
15	48-50	3	2	600/1500	1	420/1500
15	36	4	2	600/1500	2	600/1500
30	38	4	2	600/1500	2	600/1500
240	40-50	4	2	600/1500	2	600/1500
5	36-38	5	3	600/1500	2	600/1500
10	40	5	3	600/1500	2	540/1500
15	42-44	5	3	600/1500	2	480/1500
30	46	5	3	600/1500	2	480/1500
240	48-50	5	3	600/1500	2	420/1500
15	36	6	3	600/1500	3	600/1500
30	38	6	3	600/1500	3	600/1500
240	40-50	6	3	600/1500	3	600/1500
5	36	7	4	600/1500	3	600/1500
10	38	7	4	600/1500	3	600/1500
15	40-42	7	4	600/1500	3	540/1500
30	44	7	4	600/1500	3	480/1500
240	46-50	7	4	600/1500	3	480/1500
15	36	8	4	600/1500	4	600/1500
60	38	8	4	600/1500	4	600/1500
240	40-50	8	4	600/1500	4	600/1500

UPS rating 600 kVA

Max Battery Backup Time (minutes)	Battery Blocks	Battery Strings Total	Battery Breaker 1		Battery Breaker 2	
			Battery Strings	Ir/Im Setting (A)	Battery Strings	Ir/Im Setting (A)
5	36-38	2	1	600/1500	1	600/1500
10	40	2	1	600/1500	1	600/1500
15	42-44	2	1	600/1500	1	600/1500
30	46	2	1	600/1500	1	600/1500
240	48-50	2	1	600/1500	1	600/1500
5	46-50	3	2	600/1500	1	480/1500
5	36-38	4	2	600/1500	2	600/1500
10	40	4	2	600/1500	2	600/1500
15	42-44	4	2	600/1500	2	600/1500
30	46	4	2	600/1500	2	600/1500
240	48-50	4	2	600/1500	2	600/1500
5	40-46	5	3	600/1500	2	600/1500
10	48	5	3	600/1500	2	540/1500
15	50	5	3	600/1500	2	480/1500
5	36-38	6	2	600/1500	2	600/1500
10	40	6	3	600/1500	3	600/1500
15	42-44	6	3	600/1500	3	600/1500
30	46	6	3	600/1500	3	600/1500
240	48-50	6	3	600/1500	3	600/1500
5	38-42	7	4	600/1500	3	600/1500
10	44-46	7	4	600/1500	3	600/1500
15	48-50	7	4	600/1500	3	540/1500
5	36-38	8	4	600/1500	4	600/1500
10	40	8	4	600/1500	4	600/1500
15	42-44	8	4	600/1500	4	600/1500
30	46	8	4	600/1500	4	600/1500
240	48-50	8	4	600/1500	4	600/1500

With Three Battery Breaker Kits E3MBBK100K200H

UPS rating 500 kVA

Max Battery Backup Time (minutes)	Battery Blocks	Battery Strings Total	Battery Breaker 1		Battery Breaker 2		Battery Breaker 3	
			Battery Strings	Ir/Im Setting (A)	Battery Strings	Ir/Im Setting (A)	Battery Strings	Ir/Im Setting (A)
60	36-38	3	1	480/1500	1	480/1500	1	480/1500
240	40-50	3	1	480/1500	1	480/1500	1	480/1500
15	36	4	2	600/1500	1	420/1500	1	420/1500
30	38	4	2	600/1500	1	420/1500	1	420/1500
240	40-50	4	2	600/1500	1	420/1500	1	420/1500
60	36-38	5	2	600/1500	2	600/1500	1	420/1500
240	40-50	5	2	600/1500	2	600/1500	1	420/1500
60	36-38	6	2	480/1500	2	480/1500	2	480/1500
240	40-50	6	2	480/1500	2	480/1500	2	480/1500
60	36-38	7	3	600/1500	2	420/1500	2	420/1500
240	40-50	7	3	600/1500	2	420/1500	2	420/1500
60	36-38	8	3	540/1500	3	540/1500	2	420/1500
240	40-50	8	3	540/1500	3	540/1500	2	420/1500
60	36-38	9	3	480/1500	3	480/1500	3	480/1500
240	40-50	9	3	480/1500	3	480/1500	3	480/1500
60	36-38	10	4	600/1500	3	420/1500	3	420/1500
240	40-50	10	4	600/1500	3	420/1500	3	420/1500
60	36-38	11	4	540/1500	4	540/1500	3	420/1500
240	40-50	11	4	540/1500	4	540/1500	3	420/1500
60	36-38	12	4	480/1500	4	480/1500	4	480/1500
240	40-50	12	4	480/1500	4	480/1500	4	480/1500

UPS rating 600 kVA

Max Battery Backup Time (minutes)	Battery Blocks	Battery Strings Total	Battery Breaker 1		Battery Breaker 2		Battery Breaker Box 3	
			Battery Strings	Ir/Im Setting (A)	Battery Strings	Ir/Im Setting (A)	Battery Strings	Ir/Im Setting (A)
60	36-38	3	1	600/1500	1	600/1500	1	600/1500
240	40-50	3	1	600/1500	1	600/1500	1	600/1500
5	36-38	4	2	600/1500	1	420/1500	1	420/1500
10	40	4	2	600/1500	1	420/1500	1	420/1500
15	42-44	4	2	600/1500	1	420/1500	1	420/1500
30	46	4	2	600/1500	1	420/1500	1	420/1500
240	48-50	4	2	600/1500	1	420/1500	1	420/1500
15	36	5	2	600/1500	2	600/1500	1	420/1500
60	38	5	2	600/1500	2	600/1500	1	420/1500
240	40-50	5	2	600/1500	2	600/1500	1	420/1500
60	36-38	6	2	600/1500	2	600/1500	2	600/1500
240	40-50	6	2	600/1500	2	600/1500	2	600/1500
15	36-38	7	3	600/1500	2	480/1500	2	480/1500
30	40	7	3	600/1500	2	420/1500	2	420/1500
240	42-50	7	3	600/1500	2	420/1500	2	420/1500
60	36-38	8	3	600/1500	3	600/1500	2	420/1500
240	40-50	8	3	600/1500	3	600/1500	2	420/1500
60	36-38	9	3	600/1500	3	600/1500	3	600/1500
240	40-50	9	3	600/1500	3	600/1500	3	600/1500
15	36	10	4	600/1500	3	540/1500	3	540/1500
60	38	10	4	600/1500	3	480/1500	3	480/1500
240	40-50	10	4	600/1500	3	480/1500	3	480/1500
60	36-38	11	4	600/1500	4	600/1500	3	480/1500
240	40-50	11	4	600/1500	4	600/1500	3	480/1500
60	36-38	12	4	600/1500	4	600/1500	4	600/1500
240	40-50	12	4	600/1500	4	600/1500	4	600/1500

Recommended Cable Sizes for 400 V

⚠️ DANGER

HAZARD OF ELECTRIC SHOCK, EXPLOSION, OR ARC FLASH

All wiring must comply with all applicable national and/or electrical codes.

Failure to follow these instructions will result in death or serious injury.

NOTE: Overcurrent protection is to be provided by others.

Cable sizes in this manual are based on table B.52.5 of IEC 60364-5-52 with the following assertions:

- 90 °C conductors
- An ambient temperature of 30 °C
- Use of copper conductors
- Installation method C

If the ambient temperature is greater than 30 °C, larger conductors are to be selected in accordance with the correction factors of the IEC.

Cable Size for Cables Between UPS and Battery Breaker for Easy UPS 3M

Battery breaker kits	Connection	60 kVA	80 kVA	100 kVA	120 kVA	160 kVA	200 kVA
1 x E3MBBK60K80H	DC+, N, DC- (mm ²)	50	70	–	–	–	–
	PE (mm ²)	25	35	–	–	–	–
2 x E3MBBK60K80H	DC+, N, DC- (mm ²)	50	50	50	50	70	–
	PE (mm ²)	25	25	25	25	35	–
1 x E3MBBK100K200H	DC+, N, DC- (mm ²)	–	–	2 x 70	2 x 70	2 x 95	2 x 120
	PE (mm ²)	–	–	70	70	95	120
2 x E3MBBK100K200H	DC+, N, DC- (mm ²)	–	–	–	150	150	150
	PE (mm ²)	–	–	–	95	95	95

Cable Size per String for Cables Between Battery Breaker and Battery Bank For Easy UPS 3M

Number of battery strings	Connection	60 kVA	80 kVA	100 kVA	120 kVA	160 kVA	200 kVA
1 battery string	Batt+, N, Batt- (mm ²)	50	70	2 x 70	2 x 70	2 x 95	2 x 120
	PE (mm ²)	25	35	70	70	95	120
2 battery strings	Batt+, N, Batt- (mm ²)	25	35	70	70	95	120
	PE (mm ²)	16	16	35	35	50	70
3 battery strings	Batt+, N, Batt- (mm ²)	16	16	50	50	50	70
	PE (mm ²)	16	16	25	25	25	35
4 battery strings	Batt+, N, Batt- (mm ²)	16	16	35	35	35	50
	PE (mm ²)	16	16	16	16	16	25

Cable Size for Cables Between UPS and Battery Breaker for Easy UPS 3L

Battery breaker kits	Connection	250 kVA	300 kVA	400 kVA	500 kVA	600 kVA
1 x E3MBBK100K200H	DC+, DC- (mm ²)	2 x 120	2 x 120	2 x 120	–	–
	PE, N (mm ²)	120	120	120	–	–

Cable Size for Cables Between UPS and Battery Breaker for Easy UPS 3L (Continued)

Battery breaker kits	Connection	250 kVA	300 kVA	400 kVA	500 kVA	600 kVA
2 x E3MBBK100K200H	DC+, DC- (mm ²)	2 x 70	2 x 95	2 x 120	2 x 120	2 x 120
	PE (mm ²)	70	95	120	120	120
	N (mm ²)	120	120	120	120	120
3 x E3MBBK100K200H	DC+, DC- (mm ²)	–	–	–	2 x 120	2 x 120
	PE, N (mm ²)	–	–	–	120	120

Cable Size per String for Cables Between Battery Breaker and Battery Bank for Easy UPS 3L

Number of battery strings ¹	Connection	250 kVA	300 kVA	400 kVA	500 kVA	600 kVA
1 battery string	Batt+, N, Batt- (mm ²)	2 x 120	2 x 120	2 x 120	2 x 120	2 x 120
	PE (mm ²)	120	120	120	120	120
2 battery strings	Batt+, N, Batt- (mm ²)	120	120	120	120	120
	PE (mm ²)	70	70	70	70	70
3 battery strings	Batt+, N, Batt- (mm ²)	70	70	70	70	70
	PE (mm ²)	35	35	35	35	35
4 battery strings	Batt+, N, Batt- (mm ²)	50	50	50	50	50
	PE (mm ²)	25	25	25	25	25

1. Cable sizes are based on same number of battery strings for all battery breaker kits

Recommended Cable Sizes for 208 V

DANGER

HAZARD OF ELECTRIC SHOCK, EXPLOSION, OR ARC FLASH

All wiring must comply with all applicable national and/or electrical codes.

Failure to follow these instructions will result in death or serious injury.

NOTE: Overcurrent protection is to be provided by others.

Cable sizes in this manual are based on table B.52.5 of IEC 60364-5-52 with the following assertions:

- 90 °C conductors
- An ambient temperature of 30 °C
- Use of copper conductors
- Installation method C

If the ambient temperature is greater than 30 °C, larger conductors are to be selected in accordance with the correction factors of the IEC.

Cable Size for Cables Between UPS and Battery Breaker for Easy UPS 3M

Battery breaker kits	Connection	50 kVA	60 kVA	80 kVA	100 kVA
1 x E3MBBK60K80H	DC+, N, DC- (mm ²)	70	70	–	–
	PE (mm ²)	35	35	–	–
2 x E3MBBK60K80H	DC+, N, DC- (mm ²)	50	50	50	70
	PE (mm ²)	25	25	25	35
1 x E3MBBK100K200H	DC+, N, DC- (mm ²)	–	–	2X70	2X70
	PE (mm ²)	–	–	70	70

Cable Size per String for Cables Between Battery Breaker and Battery Bank For Easy UPS 3M

Number of battery strings	Connection	50 kVA	60 kVA	80 kVA	100 kVA
1 battery string	Batt+, N, Batt- (mm ²)	70	70	2X70	2X70
	PE (mm ²)	35	35	70	70
2 battery strings	Batt+, N, Batt- (mm ²)	35	35	70	70
	PE (mm ²)	16	16	35	35
3 battery strings	Batt+, N, Batt- (mm ²)	16	16	50	50
	PE (mm ²)	16	16	25	25
4 battery strings	Batt+, N, Batt- (mm ²)	16	16	35	35
	PE (mm ²)	16	16	16	16

Torque Specifications

Bolt Size	Torque
M8	20 Nm
M10	30 Nm

Environment

	Operation	Storage
Temperature	0 °C to 40 °C	-25 °C to 55 °C

Installation Procedure

NOTE: The illustrations in this manual shows the installation in a 700 mm empty battery cabinet. The battery breaker kit can also be installed in a 1100 mm empty battery cabinet or in a grounded metal box.

1. Mount the battery breaker kit. Follow one of the procedures:
 - Mount the Battery Breaker Kit in a Grounded Metal Box, page 34, or
 - Mount the Battery Breaker in the Empty Battery Cabinet – Bottom Cable Entry, page 35, or
 - Mount the Battery Breaker in the Empty Battery Cabinet – Top Cable Entry, page 36.
2. Connect the Signal Cables, page 37.
3. Connect the Power Cables, page 40.

Mount the Battery Breaker Kit in a Grounded Metal Box

▲ CAUTION
RISK OF EQUIPMENT DAMAGE
Mount the battery breaker kit in a grounded metal box with enough cable bending space and clearance. The mounting surface should be flat and able to support the weight of the battery breaker kit.
Failure to follow these instructions can result in injury or equipment damage.

	Minimum Dimensions of Metal Box HxWxD (mm)	Minimum Ventilation Surface (mm ²)
Battery breaker kit E3MBBK60K80H	650x500x280	65000
Battery breaker kit E3MBBK100K200H	800x500x280	120000

E3MBBK60K80H

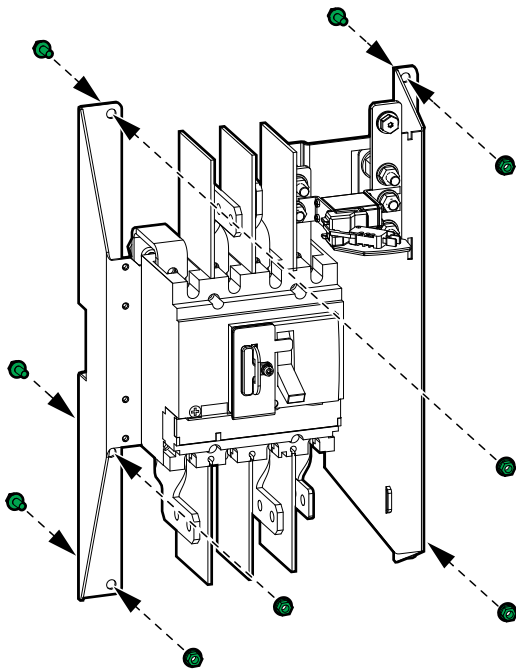

E3MBBK100K200H

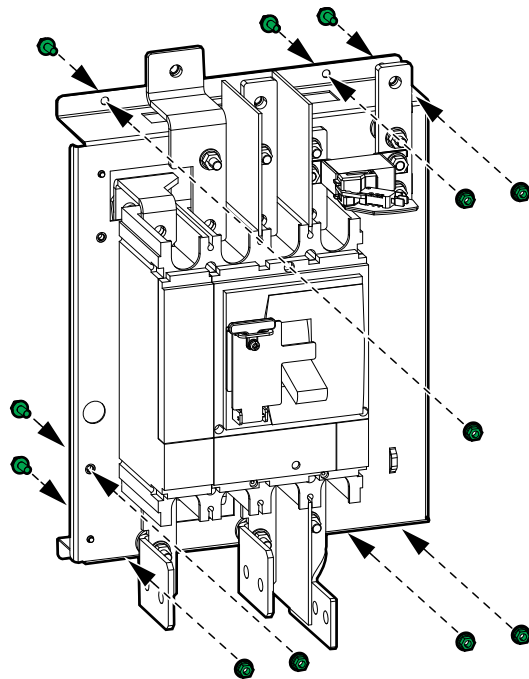

1. Measure and mark the holes for mounting the battery breaker kit in the metal box.
2. Drill holes in each of the marked locations.
3. Mount the battery breaker kit in the metal box.

Mount the Battery Breaker in the Empty Battery Cabinet – Bottom Cable Entry

1. Install the battery breaker kit in the bottom of the empty battery cabinet.

Front View of the Empty Battery Cabinet

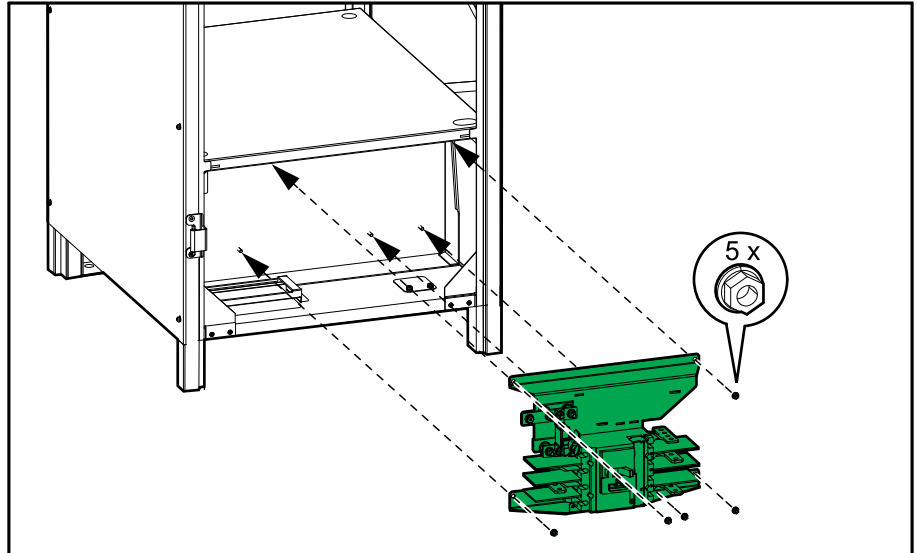

Mount the Battery Breaker in the Empty Battery Cabinet – Top Cable Entry

1. Install the battery breaker kit in the top of the empty battery cabinet.

Front View of the Empty Battery Cabinet

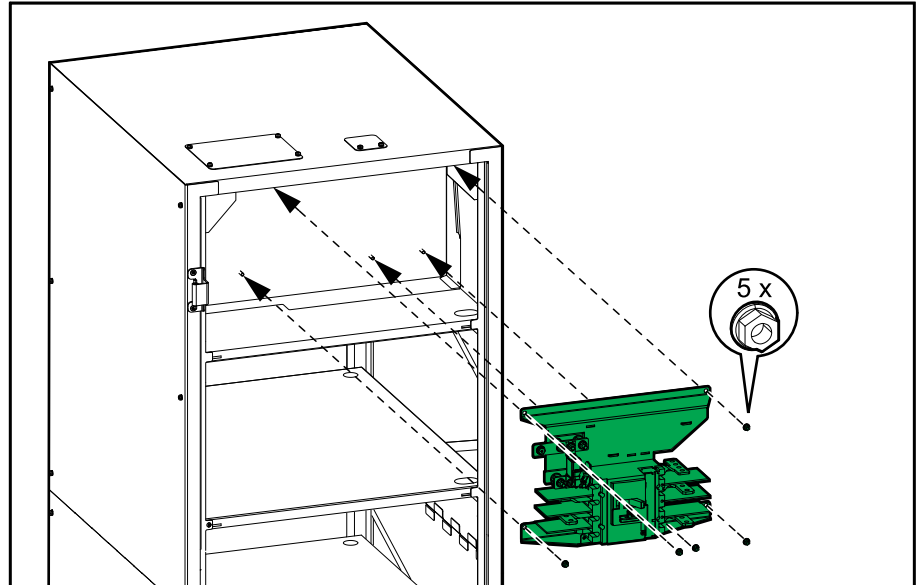

Connect the Signal Cables

NOTE: Route the signal cables separately from the power cables.

NOTE: The illustrations in this procedure show a bottom cable entry system. The procedure is the same for a top cable entry system.

1. Install the temperature sensor provided with the UPS.

⚠ WARNING

HAZARD OF FIRE

Position the temperature sensor as described to ensure correct temperature measurements.

Failure to follow these instructions can result in death, serious injury, or equipment damage.

Front View of the Empty Battery Cabinet

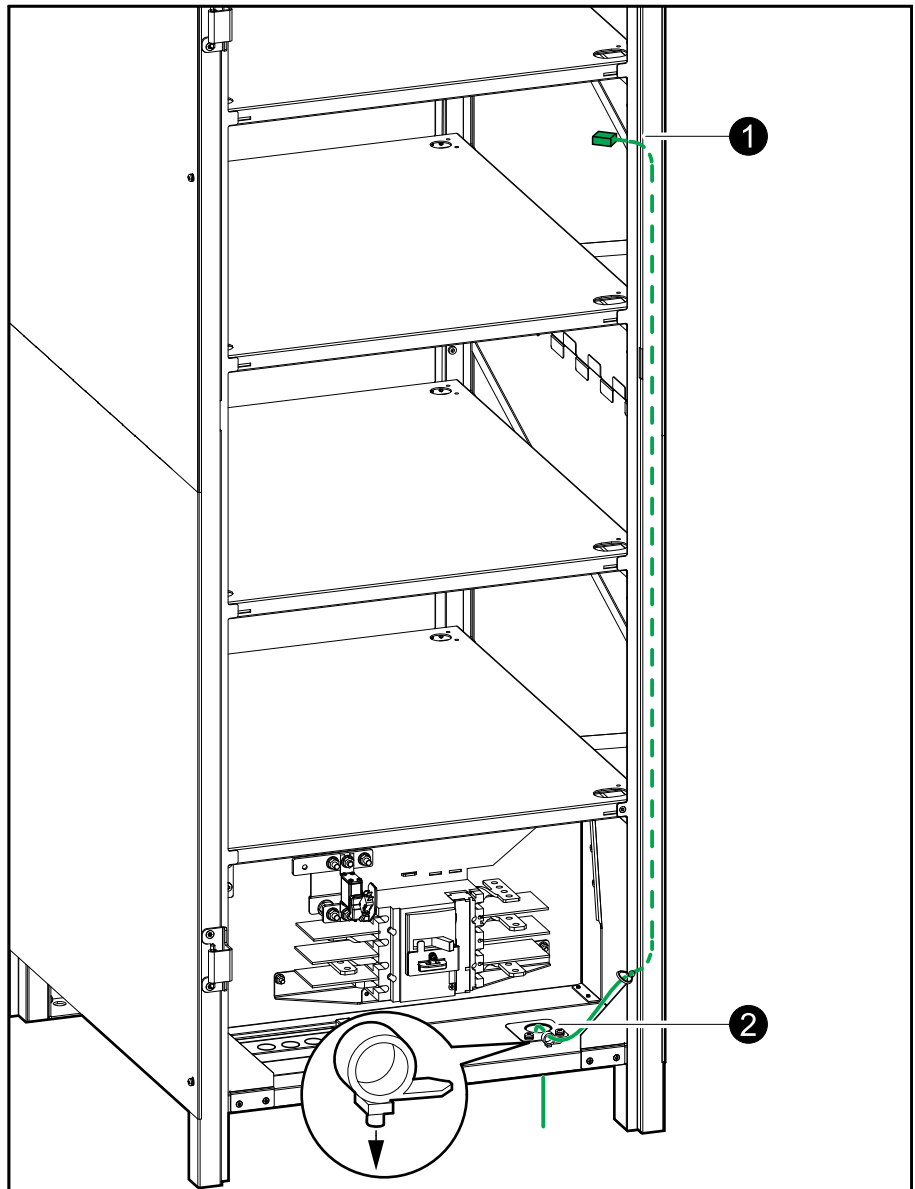

2. Route the battery temperature sensor cables through the top or the bottom of the empty battery cabinet to the UPS dry contact terminals BAT_T for Easy UPS 3M and J12 for Easy UPS 3L.

3. Route the signal cables through the top or bottom of the empty battery cabinet to the battery breaker.
4. Remove the cover from the battery breaker.

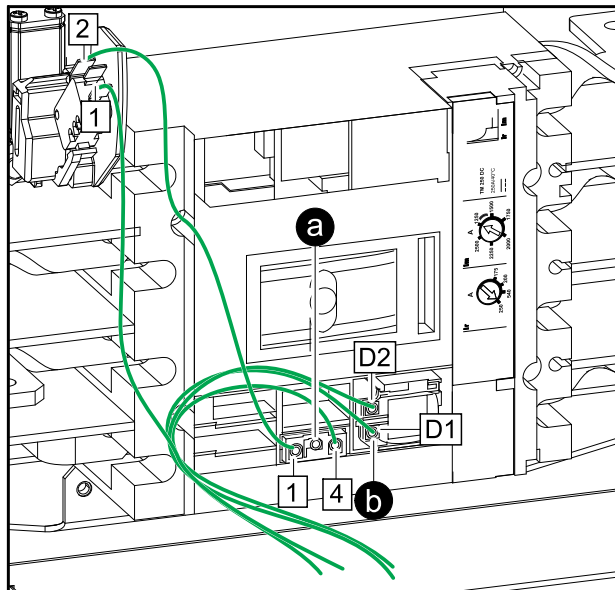

5. Connect the signal cables according to one of the diagrams below for **Easy UPS 3M**:

Signal Cables in Installations with One Battery Breaker

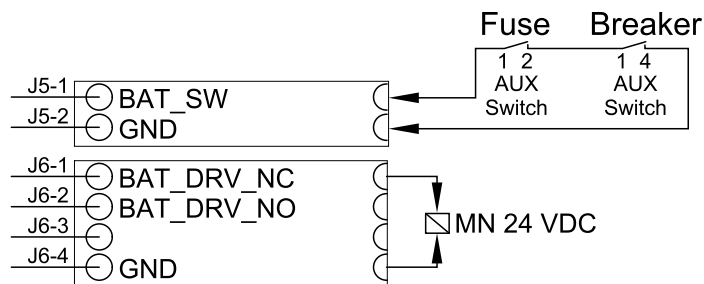

Signal Cables in Installations with Two Battery Breakers

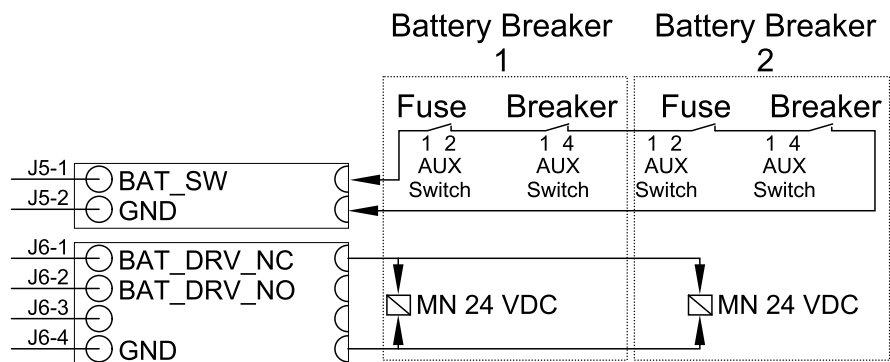

- a. Connect the AUX switch signal cables from the battery breaker(s) and fuse(s) to J5-1 and J5-2 in the UPS.
- b. Connect the undervoltage trip coil signal cables from the battery breaker (s) to J6-1 and J6-4 in the UPS.

6. Connect the signal cables according to the diagram below for **Easy UPS 3L**.

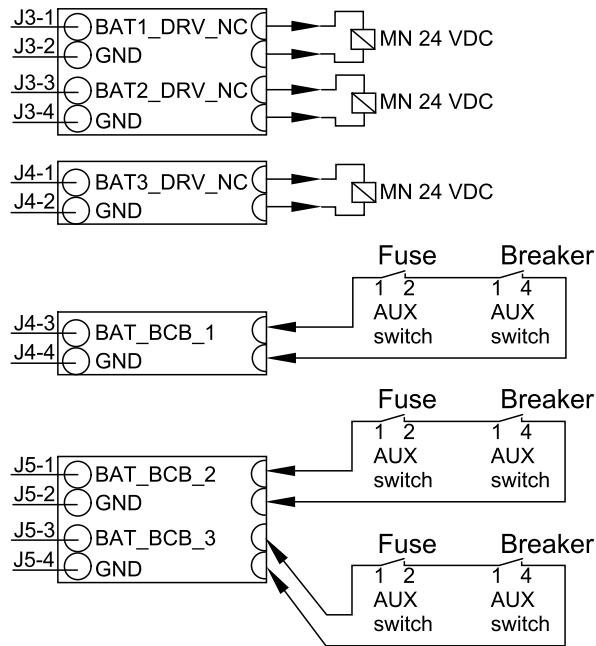

- a. Connect the AUX switch signal cables from the battery breakers and fuse (s) to J4-3 and J4-4, J5-1 and J5-2, and J5-3 and J5-4 in the UPS.
 - b. Connect the undervoltage trip coil signal cables from the battery breaker s to J3-1 and J3-2, J3-3 and J3-4, and J4-1 and J4-2 in the UPS.
7. Fasten the signal cables with cable ties (provided) to the cable relief.
 8. Reinstall the breaker cover on the battery breaker.

Connect the Power Cables

⚠ DANGER

HAZARD OF ELECTRIC SHOCK, EXPLOSION, OR ARC FLASH

Perform a total power off of the UPS system before connecting the battery cables to the battery breaker.

Failure to follow these instructions will result in death or serious injury.

1. Lockout/Tagout the battery breaker in the OFF position.

Empty Battery Cabinet – Bottom Cable Entry

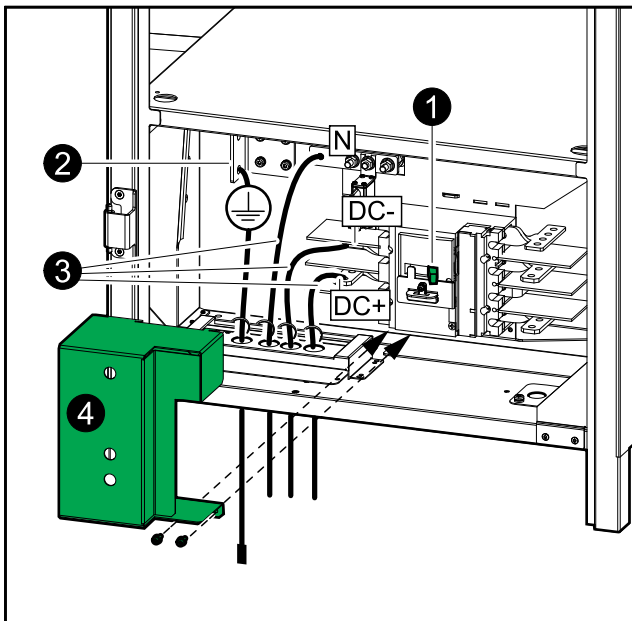

Empty Battery Cabinet – Top Cable Entry

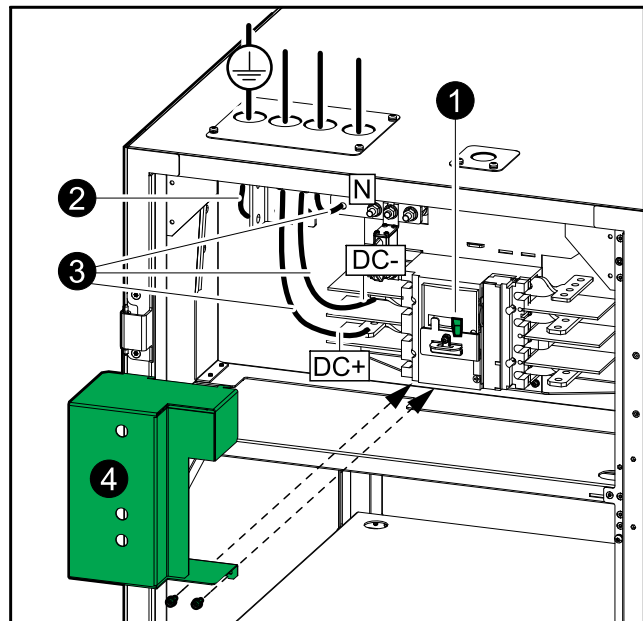

2. Connect the PE cable.
3. Connect the DC cables (DC+, N, DC-) from the UPS.
4. Install the protection cover over the terminals on the left side of the battery breaker.
5. Install the batteries as described in the installation manual supplied with the empty battery cabinet.

6. Connect the battery cables (Batt+, N, Batt-) from the batteries in the empty battery cabinet to the battery breaker.

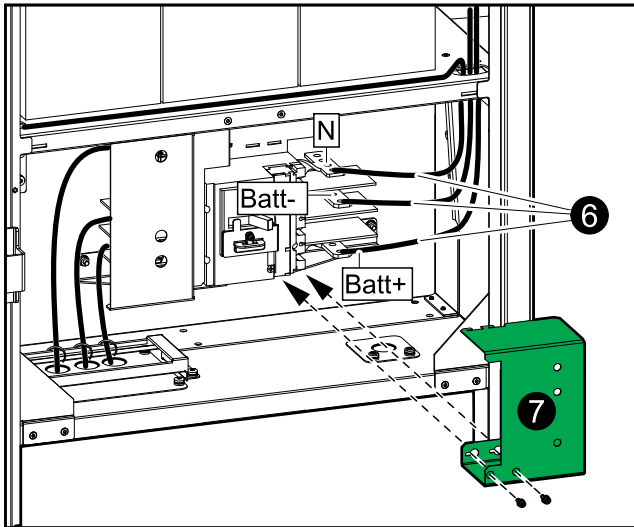
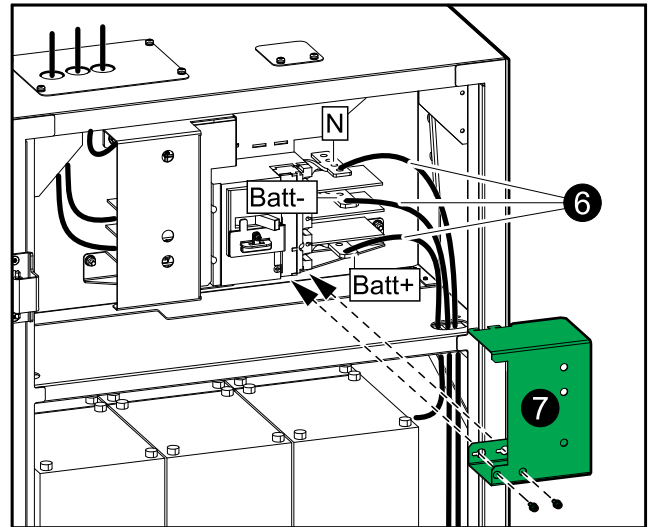
Empty Battery Cabinet – Bottom Cable Entry**Empty Battery Cabinet – Top Cable Entry**

7. Install the protection cover over the terminals on the right side of the battery breaker.

Schneider Electric
35 rue Joseph Monier
92500 Rueil Malmaison
France

+ 33 (0) 1 41 29 70 00



As standards, specifications, and design change from time to time,
please ask for confirmation of the information given in this publication.

© 2019 – 2021 Schneider Electric. All rights reserved.

990-5997D-001